

Fixed vs. Floating Rail Arrangements

The authors of this paper have more than 50 years of combined involvement in structural design for heavy industrial projects. Most of their engineering experience is related to repairs and upgrading of existing mill buildings equipped with overhead traveling cranes.

This paper reviews two different types of rail fasteners, which provide “fixed” or “floating” rail attachments to the crane runway, and their effect on the wheel/rail interface.

The upgrade/repair process is an excellent way to learn about design of the investigated structures. Premature failure of mill building structures is usually the result of inadequate attention (or negligence) to details and, particularly, a lack of recognition that the crane

supporting system is a part of the machine, not the static structure.

The interaction between the crane and the building structure (crane runway) is provided by the crane wheel/rail interface. The way the rail is fastened to the crane girder is often neglected (or ignored) by the design engineers — mechanical as well as structural. However, it has a significant effect on the crane and runway performance.

Two different types of rail fasteners, which provide “fixed” or “floating” rail attachments to the crane runway, and their effect on the wheel/rail interface are reviewed in this paper.

The Rail Attachments

The oldest type of crane rail fixing on the crane girder is hook bolts, which have been found in old (more than 100 years old) mill building crane runways (Figure 1a).

The next generation of rail fasteners (found in the AISC 1937 reference book) was a bent

Figure 1

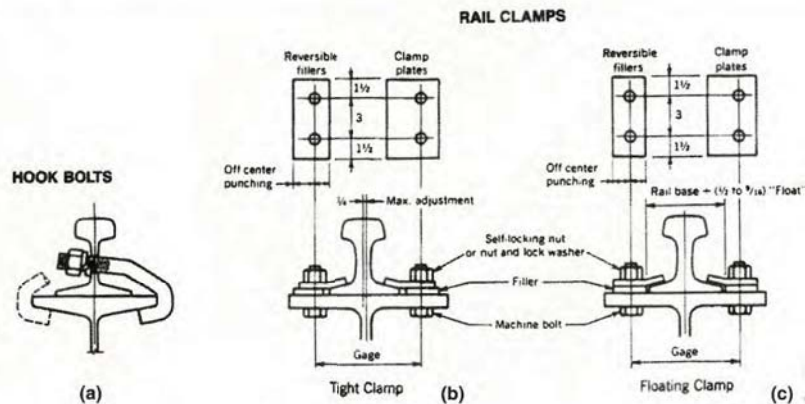

Rail attachments per AISC 1937–2005 manuals.



Authors

Raymond Milman (left) and Charles Hoppel (right), Middough Inc., Cleveland, Ohio (hoppelc1@middough.com)

Figure 2

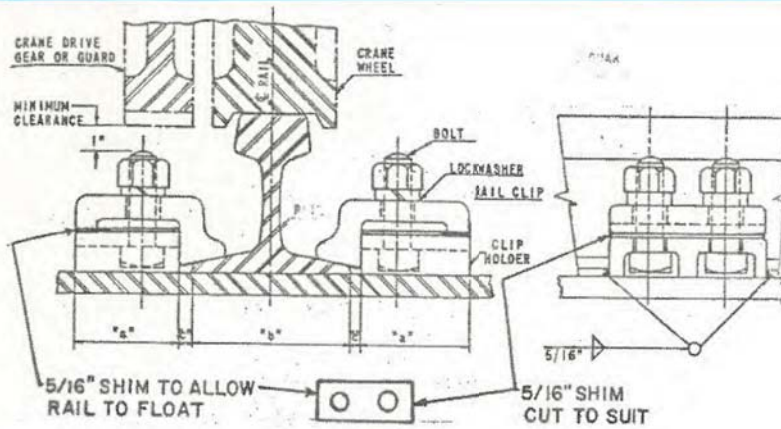

Bethlehem forged rail clips with possible conversion from "fixed" to "floating" type.

plate clamp, which can be a "tight clamp" (Figure 1b) or "floating clamp" (Figure 1c). The floating type permits longitudinal and controlled transverse movement through clamp clearances and filler adjustment. It is useful in allowing for thermal rail expansion or contraction and a possible runway misalignment, according to the 1937 source of information.

The 1955 Bethlehem Crane Rail catalog shows two types of rail clips: pressed from the steel plate and forged. According to the Bethlehem catalog, "Crane runway installation may be either 'tight' or 'loose' type. In the former, the rails are anchored to the runway; in the latter, provisions are made for

sufficient lateral and longitudinal movement to permit the rail thermal expansion and contraction, as well as to prevent binding of wheel flanges."

These Bethlehem clips still can be found in many U.S. plants equipped with overhead cranes. It should be mentioned that forged clips (types No. 201 and No. 202) have been designed as "tight" clips. However, they can be converted into the "loose" type by an installation of the fill plate between the clip holder and the rail clip (Figure 2). This method was successfully used in the Bethlehem Burns Harbor plant for many years.

Figure 3

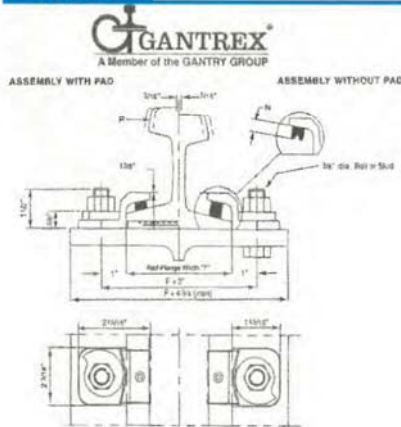

Gantrex rail clip.

Figure 4

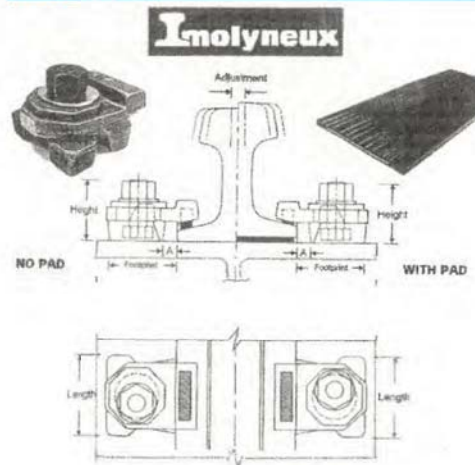

Molyneux rail clip.

Figure 5

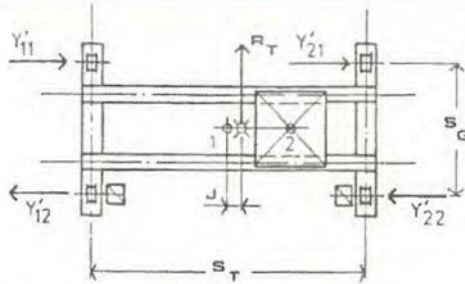

Lateral forces due to dynamic asymmetry.

Figure 6

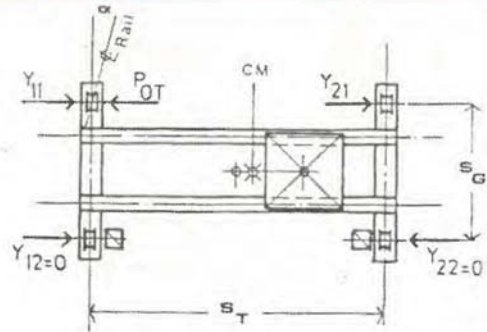

Lateral forces due to oblique traveling of a 4-wheel bridge crane.

The latest types of the rail clips have been introduced by Gantrex Inc. (Figure 3) and Molyneux Industries Inc. (Figure 4). All these forged and cast steel rail clips of different configurations are designed to provide a freedom for rail longitudinal expansion or contraction and to prevent lateral movement after the rail has been adjusted to a fixed position.

The issue of fixed vs. floating rail attachments (clips) has been debated by experts for many years.

The 2005 AISC Steel Construction Manual still includes "tight" and "floating" clamps, which were shown in the 1963 AISC manual. However, the majority of the latest sources support the fixed (tight) rail attachment idea as the best way to minimize the rail head and the wheel flange wear.

The following are quotes from some of the reference sources:

- CMAA Specification #70, 2004 Section 1.4.2: "Floating rails are not recommended."⁴
- AIST Technical Report No. 13, 2003, Par.5.16.3: "Rail clips, clamps or attachments shall permit the rail to expand and contract longitudinally and limit lateral float to $\pm 1/8$ " (inch)."¹
- Whiting Crane Handbook, 1985: "Floating rails should not be used for runways. Their use can cause rapid wheel wear and overheating of the bridge motor due to the crane running out of square."⁷
- Griggs, P.H., "Support Your Overhead Crane," 1978: "To minimize the steering forces, lateral horizontal rail float should not be permitted by the rail clips."¹³
- Rowswell, J.C., *Crane Runway Systems*, 1987: "The rail clips must restrain the rail from moving transversely, but still allow for longitudinal movement. Thus clips

should lightly bear against the sides of the lower flanges (base) of the rail."¹⁴

On the other hand, "The entire Burns Harbor plant has $\pm 3/8$ -inch laterally floating rails (Figure 2) and this seems to work rather well."¹⁰ To reduce wheel flange-to-rail head friction, wheel flange lubrication with Trans-Lube sticks are widely used in the plant. This lubrication is applied directly to the wheel flanges, and its film is transmitted to the contact side of the rail head during the crane running. As a result of this, crane rails do not have wear on the side of the head, and thin wheel-flange failures are not excessive as in most steel plants (C. Totten letter to R. Milman, March 9, 2008).

To better understand the wheel-rail interaction mechanism, let's review the crane downshop motion and forces generated by this motion.

The Crane Motion

The traction generated by the drive units for the crane longitudinal travel should ideally have the result of the wheel tractive forces being applied at the center of the crane mass to avoid the crane rotation in the horizontal plane. However, this ideal case can be achieved only in the test conditions, not in real life.

When the result of tractive forces does not pass through the center of mass (Figure 5), a torsional moment in the horizontal plane is generated each time the crane accelerates or brakes. This torsional moment creates lateral forces delivered to the crane runway rails by the crane wheels and makes the crane possess a skew position.

The sequence of events during the crane oblique travel (Figure 6) is generally as follows:

- The crane assumes a skew position, for any reason such as the crane mass

Figure 7

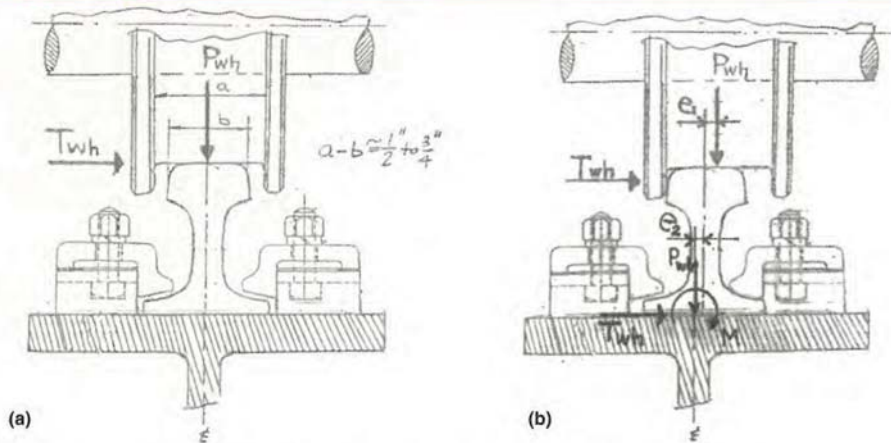

Forces at wheel/rail interface (a), and force diagram after wheel and rail slide (b).

dynamic asymmetry (Figure 5), the crane and/or crane runway misalignment (even within allowable tolerances), and the clearance between wheel flanges and the rail head. After that, the crane continues an oblique travel until the leading wheel flange comes in contact with the side of the rail head.

- The lateral force (sometimes called a steering force) on the side of this rail, generated by friction at skew angle, reaches a peak value and provides frictional resistance to the crane forward movement.
- Due to action of this force, the crane returns to its proper course, at least temporarily, until the next cycle of skewing motion.

The Skewing Forces

To achieve a lateral rail movement, allowed by floating rail installation, the magnitude of the lateral horizontal wheel force (skewing or straight side thrust forces) shall be larger than the wheel vertical load times the coefficient of friction between the rail base and the top of crane runway girder (Figure 7).

The analytical determination of the crane skewing forces is the "grayest" area among the present design codes and specifications.

AIST Technical Report No. 6 (TR 6) and *CMAA Specification #70* propose oversimplified approaches.^{2,4} *TR 6* considers only lateral forces at the four corners of the bridge frame due to dynamic asymmetry. *CMAA Specification #70* provides a skew force factor as a function of the ratio of the crane span to the wheel base.

None of these documents provide determination of the steering force, which basically

creates the crane rotation in the horizontal plane and causes friction (grinding) between the wheel flanges and the rail head.

Skewing forces determined by using the above documents, in most cases, do not exceed the value of crane vertical load multiplied by the coefficient of the friction, which means that no lateral slide of the rail should be expected and there is no reason to make floating rail installations. However, the grinding of the rail head and wheel flanges is observed due to friction of skew-positioned wheels during the crane motion, regardless of the "fixed" or "floating" rail installation.

AIST Technical Report No. 13 (TR 13) does not address the skewing forces at all.¹ It is hoped that the extremely conservative *TR 13* straight side thrust provisions would cover the effect of skewing forces. There is no evidence of the structural failures of buildings designed per *TR 13*, except broken rail-clip-to-girder connections found during periodic crane runway inspections, which show a significant magnitude of skewing forces.

A more accurate determination of the skewing forces is offered by the *German Standard DIN 15018*.⁹

If the crane takes a skew position relative to the crane runway, a contact (steering) force is produced on the front wheel flange, and the remaining crane wheels develop reactive lateral forces to resist the crane rotation in the horizontal plane (Figure 8).

The magnitude of the steering force is a function of the skew angle. The larger the skewing angle, the larger the coefficient of contact friction of the wheel flange against the rail head. This coefficient of friction fluctuates from 0.09 to 0.30. The steering lateral force at the front wheel, determined in accordance

Figure 8

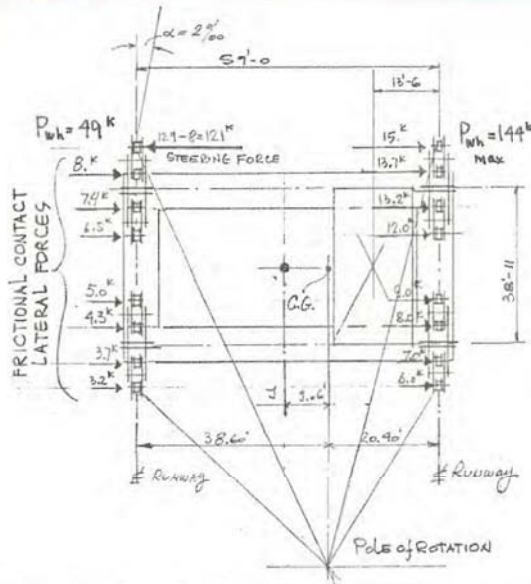

Skewing forces due to DIN 15018 (250-ton ladle crane).

with this approach, could achieve a significant magnitude, which would be large enough to move the rail in the lateral direction, if it is permitted. Figure 8 shows a skewing force diagram for the 16-wheel, 250-ton ladle crane, developed using the DIN 15018 approach. The steering wheel force of 121 kips is large enough to cause the lateral movement of the rail.

The field observations of the floating rail installations confirmed the rail lateral movements, and this creates a valid concern about the accuracy of the skewing force prediction by *TR 6* and *CMAA*.

The Fixed vs. Floating Rail Installation

It was observed at many plants that frictional wear of the wheel flanges and rail heads takes place regardless of the type of the rail installation pattern. The argument that the lateral float allows the rail to find its own position under action of high skewing forces, which reduces wheel-to-rail friction forces, is incorrect. As the skew angle increases, as a result of the rail lateral float, the magnitude of the skewing steering force and the contact pressure between the wheel flange and rail head also increases, changing a polishing action to rail head grinding.

The lateral float of the rail could create an excessive eccentricity of the rail vs. the girder web centerline (Figure 7b), which is limited by *TR 13* (Ref. 1) to 3/4 of the web thickness.¹ This eccentricity will cause a cyclic torsional moment at the girder top-flange-to-web connection at each crane passage over the girder, which could result in fatigue cracking of this connection.

At the present time, major rail clip manufacturers (Gantrex and Molyneux), based on their research results, recommend only fixed types of rail clips, which allow an adjustment in the lateral direction during installation and permanent freedom for the longitudinal rail movement.

The rail installation on the crane girder top flanges (fixed or floating) is only one of many factors affecting the rail head and wheel flange wear. To reduce the high crane skewing forces as a major contributor to rail and wheel wear, the following measures should be considered:

- Crane rail should be installed at the "fixed" position to ensure a proper crane runway span within tolerances recommended by *TR 13* Para 5.18.6 and *CMAA* Para 1.4.2.^{1,4}
- Crane bridge frame and wheel alignment should be maintained in agreement with *TR 6* Para 3.7.2, Figure 01S-1

Figure 9

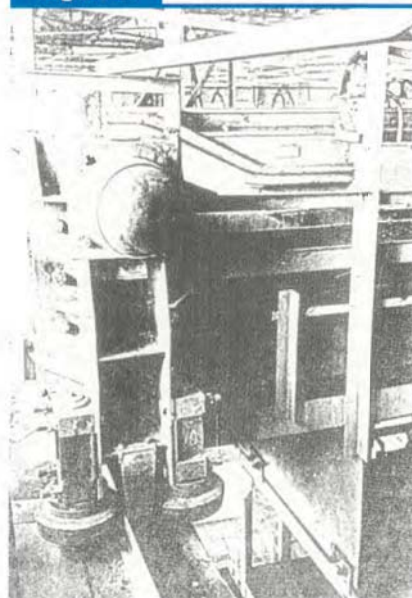

Vertical roller guides.

and Figure O1S-2 recommended tolerances.²

- Installation of crane bridge wheel/rail lubricators (such as Trans-Lube graphite sticks), which significantly reduces contact friction, should be considered.
- An installation of vertical roller guides (widely used in Europe; Figure 9) will provide the centered crane wheel position over the rail, and this practically would eliminate contact friction between rail and wheel flanges. If required, replacement of rollers is much easier to perform than crane wheel replacement.

Conclusion

This paper has addressed a debatable issue of the crane-rail-to-crane-girder top flange attachments, and how it is viewed by two structural engineers with some crane runway-related experience. This important subject, which affects one of the most time- and cost-consuming maintenance problems, does not get proper attention from engineers involved in crane/runway interaction.

The rail/wheel contact friction wear can be reduced or eliminated through improving crane guidance by driving systems and a proper maintenance of the crane and runway.

Acknowledgment

The authors express a great appreciation to Mr. C. Totten (Morris Material Handling) and Mr. T. Berringer (Gantrex) for their help in preparation of this paper.

References

1. AIST Technical Report No. 13, *Guide for Design and Construction of Mill Buildings* (2003).
2. AISE Technical Report No. 6, *Specification for Electrical Overhead Traveling Cranes for Steel Mill Service* (October 2000).
3. AISC Steel Construction Manuals (1937–2005).
4. CMAA Specification #70, *Specifications for Top Running and Gantry Type Overhead Traveling Cranes* (2004).
5. Gantrex, crane runway products (January 2008).
6. Molyneux, crane rail clips, rail pads and tieback links.
7. *Whiting Crane Handbook* (1995).
8. Gantrex, *Bulletin No. 36/88* (Revised: June 1989), "Why Crane Rails Should Be Fixed Laterally."
9. DIN 15018 (Germany) *Cranes: Principles for Steel Structures, Stress Analysis* (1974).
10. Totten, C.A., "10-Year History of Crane Wheel Assembly Maintenance at Bethlehem's Burns Harbor Plant," *Iron and Steel Engineer*, Vol. 68, No. 2, 1991.
11. Kivenson, B.M., "Crane Wheel and Rail Interface," *Iron and Steel Engineer*, Vol. 68, May 1991.
12. Gorens, B.E., *Crane Runway Girders*, Australian Institute of Steel Construction (1983).
13. Griggs, P.H., "Support Your Overhead Crane," *AISE Annual Convention*, Chicago (1978).
14. Rowswell, J.C., "Crane Runway Systems," University of Toronto (1987). ♦

This paper was presented at AIST's 15th Annual Crane Symposium — Training for the Future, June 1–3, 2008, Pittsburgh, Pa.



Did you find this article to be of significant relevance to the advancement of steel technology? If so, please consider nominating it for the AIST Hunt-Kelly Outstanding Paper Award at www.aist.org/huntkelly.